

SKYTEAM

**ST50 SM/TR
OPERATION INSTRUCTION**



SKY TEAM CORPORATION LTD.

1104 CARNIVAL COMMERCIAL BLDG.

18 JAVA ROAD NORTH POINT HONGKONG

TEL:00852 25089428

FAX:00852 25089478

EMAIL:SKYTEAM_HK@HOTMAIL.COM

HTTP://WWW.SKYTEAM.NET.CN

//WWW.SKYTEAM.CN

SKYTEAM MOTORCYCLE

TABLE OF CONTENTS

OPERATION

Page		Page	
1	Important Precautions	27	Pre-ride Inspection
2	Consumer Information	29	Starting the Engine
6	Parts Location	32	Running - in
9	MAJOR COMPONENTS (Information you need to operate this motorcycle)	33	Riding
9	Brakes	35	High Altitude Riding
12	Clutch	36	Braking
14	Fuel	37	Parking
17	Engine Oil	37	Anti-theft Tips
18	Tires		
23	ESSENTIAL INDIVIDUAL COMPONENTS		
23	Ignition Switch		
24	Instrument panel		
25	Left handlebar		
26	Right handlebar		
27	OPERATION		

MAINTENANCE

Page		Page	
38	MAINTENANCE	63	Front Suspension
38	The Importance of maintenance	64	Rear Suspension
39	Maintenance Safety	65	Side Stand
40	Safety Precautions		
41	Maintenance Schedule	66	CLEANING
44	Serial Number	69	STORAGE GUIDE
45	Air Cleaner	69	Storage
46	Engine Oil	70	Removal from Storage
49	Spark Plug		
51	Idle Speed	71	SPECIFICATIONS
52	Throttle Operation		
54	Drive Chain		
59	Wheel Rims and Spokes		
60	WHEEL REMOVAL		
60	Front Wheel Removal		
61	Rear Wheel Removal		

IMPORTANT PRECAUTIONS

BREAK-IN INFORMATION FOR YOUR MOTORCYCLE

The first 1,600km is the most important in the life of your motorcycle. Proper running-in operation during this time will help ensure maximum life and performance of your new motorcycle

Motorcycle reliability and performance depend on special care and restraint exercised during running-in period. It is important that you avoid operating the engine in the manner which could expose the engine parts to excessive heat.

Please refer to the “running-in” section for specific running-in recommendation.

Please read this manual and following its instructions carefully.

To emphasize special information, the words WARNING and NOTICE carry special meaning and should be carefully reviewed.

WARNING:

The personal safety of the rider may be involved, disregarding this information could result in injury to the rider.

NOTICE:

These instructions point out special service procedures or precautions that must be followed to avoid damaging the machine and make maintenance easier or important instructions clearer.

CONSUMER INFORMATION

ACCESSORY INSTALLATION AND SAFETY PRECAUTION TIPS

There are great varieties of accessories available to SKYTEAM owners. The addition of unsuitable accessories can lead to unsafe operating conditions. For proper installation of accessories, we have laid down some principles which will help you for the correct choice and installation of accessories.

(1) If you want to install an accessory which will result in an extra weight or an aerodynamic effect to your motorcycle, try to install it as low as possible and as close as possible to the center of gravity of your motorcycle. Check carefully the holder for installing accessories to make sure for its firmness. The infirm installation will lead to unstable and dangerous conditions due to weight deviation.

(2) Check the net clearance and turning angle to make sure that they are adequate. The improper load, which may occur after installing accessories, will very likely lower their safety factors. Checks should also be made that this

improper load will not hinder the idling, tuning and other control actions.

(3) Fixing the accessories on handlebars or front fork will result in unstable operation. This extra weight will reduce the maneuverability of your motorcycle during turning operations, meanwhile, this extra weight will also cause unstable condition due to vibration at the front end. Therefore, fixing accessories on handlebars or front fork should be minimized.

(4) Things like windglass, windshield, waist support, bags across seat and suitcases all have an aerodynamic effect on the stability of your motorcycle, when there is a side wind or large vehicles passing by. The improper installation or bad design of accessories will affect your driving safety. Therefore, you should be careful for the choice and installation of accessories.

(5) Certain accessories displace the rider from his normal riding position. This will not only limit the freedom of movement of the rider, but also his control ability.

(6) Extra electrical accessories may overload the

existing electrical system. Severe overloads may damage the wiring harness or create a dangerous situation due to the loss of electrical power during the operation of the motorcycle.

When carrying a load on the motorcycle, mount it as low as possible to the motorcycle. An improperly mounted load can create a high center of gravity which is very dangerous and make the motorcycle difficult to handle. The size of a load can affect the aero-dynamics and the handling of the motorcycle. Balance the load between the left and right side of the motorcycle and fasten it firmly.

SAFE RIDING RECOMMENDATIONS FOR MOTORCYCLE RIDERS

Motorcycle riding is a great joy and an exciting sport. Motorcycle riding also requires that some extra precautions be taken to ensure the safety of the rider. These precautions are:

WEAR A HELMET

Motorcycle safety equipment starts with a quality safety helmet. One of the most serious injuries that can happen is head injury. Always **wear a properly approved helmet. You should also wear suitable eye protection.**

RIDING APPAREL

Tight, fancy clothing can be uncomfortable and unsafe when riding your motorcycle. Choose good quality motorcycle riding apparel when riding your motorcycle.

CHECKS BEFORE RIDING

Review thoroughly the instructions in the "PRE-RIDE INSPECTION" section of this manual. Do not forget to perform all the safety checks to ensure the safety of the rider

FAMILIARIZE YOURSELF WITH THE MOTORCYCLE

Your riding skill and your mechanical knowledge form the safe riding practices. We suggest that you practice riding your motorcycle in a non-traffic situation without obstacles until you are thoroughly familiar with your machine and its controls. Remember that practice makes perfect.

KNOW YOUR SAFETY SPEED LIMITS

Ride within the boundaries of your own skill at all times. Knowing these limits and staying within them will help you to avoid accidents.

BE EXTRA SAFETY CONSCIOUS ON BAD WEATHER DAYS

Riding on bad weather days, especially wet ones, requires extra caution. Braking distance doubles on a rainy day. Stay off the painted surface marks, manhole covers and greasy appearing areas as they can be especially slippery. Use extreme caution at railway crossings and on metal grating and bridges. Whenever in doubt about road condition. **SLOW DOWN!**

AUTOMOBILE/MOTORCYCLE ACCIDENTS PREVENTION

Many automobile/motorcycle accidents happen because the automobile driver does not "SEE" the motorcyclist

Make yourself conspicuous to help avoid the accident that wasn't your fault:

- .Wear bright or reflective clothing
 - .Don't ride in another motorist's "blind spot".
 - .Signal before you make a turn or lane change.
- Your size and maneuverability can surprise other motorists.

MODIFICATION

Modification of the motorcycle, or removal of original equipment may render the vehicle unsafe or illegal .Obey the local regulations for available equipment.

PARTS LOCATION

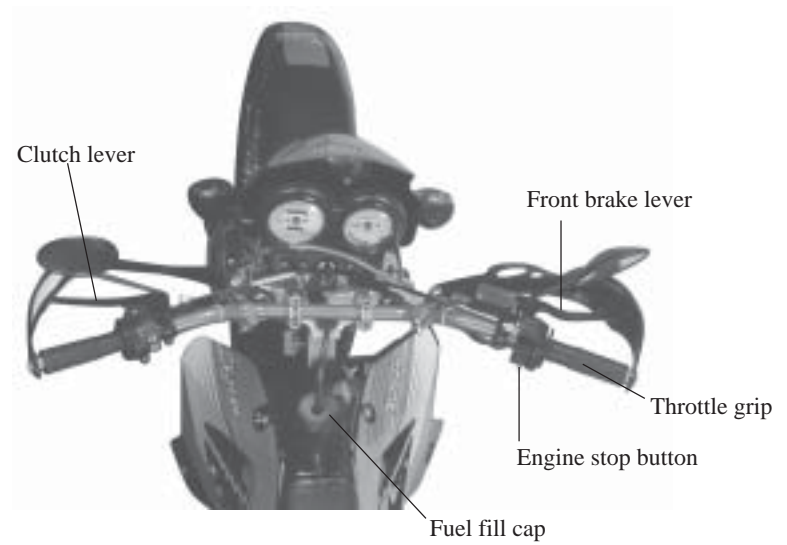

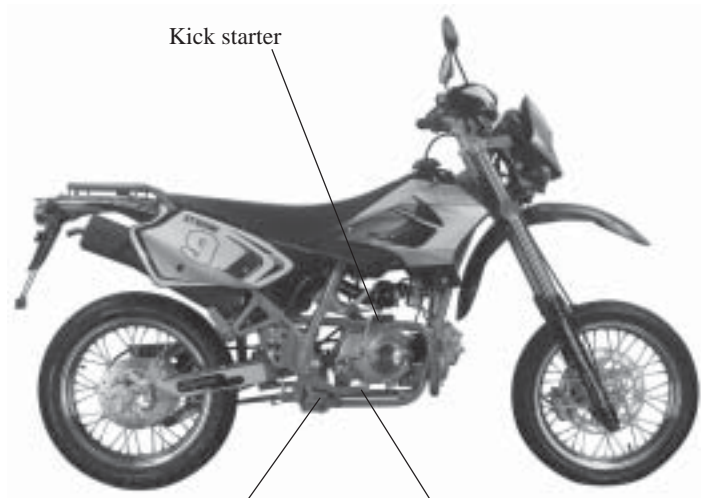

Kick starter

Footpad

Rear brake pedal

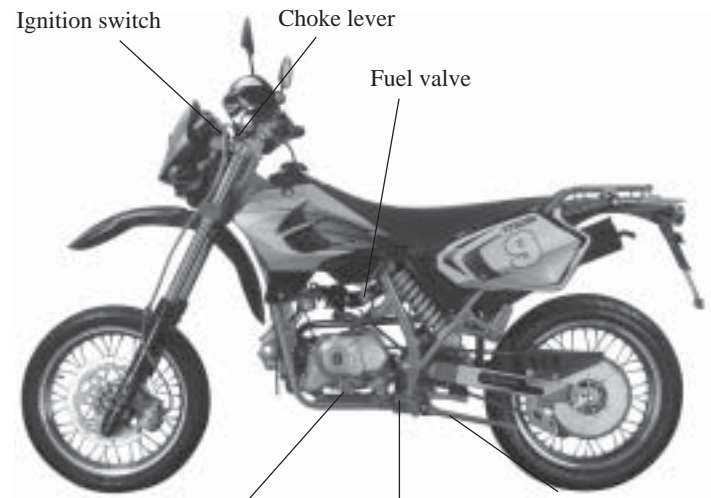

Ignition switch

Choke lever

Fuel valve

Gearshift pedal

Footpad

Side stand

MAJOR COMPONENTS

(Information you need to operate this motorcycle)

BRAKES

This motorcycle has a hydraulic brake system of front and rear. Brakes are items of personal safety and should be properly adjusted. Remember to check periodically the brake system and these checks should be conducted by qualified Jincheng dealer.



Front brake



Rear brake

BRAKE FLUID

▲ WARNING

Brake fluid may cause irritation. Avoid contact with skin or eyes. In case of contact, flush thoroughly with water and call a doctor if your eyes were exposed

NOTICE

Do not use the remained brake fluid from on a unsealed container, never reuse the brake fluid remained in the last repairing, because the used brake fluid may absorb the water from the air. Use DOT 4 brake fluid from a sealed container. Do not spill out the brake fluid, when the brake fluid is glued to the paint, plastic and rubber material, a chemical reaction shall take place, causing the damage.

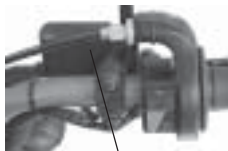

(1)lower level mark

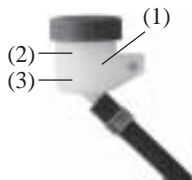

(1)Brake fluid cap

(2)Max. fluid level mark

(3)Min. fluid level mark

FRONT BRAKE FLUID LEVEL

Check that the fluid level is above the lower level mark(1) with the motorcycle in an upright position.

Brake fluid must be added to the reservoir when ever the fluid level begins to reach the lower level mark(1). Fill the reservoir up to upper level mark.

REAR BRAKE FLUID LEVEL

There are two marks in rear brake fluid cap,keep the fluid lever between the Max. fluid level mark(2) and the Min. fluid level mark (3) always.

NOTICE

Check if it is short of brake fluid, check the hose and other components for corrosion or cracks.

BRAKE LINING



Front brake



Rear brake



Brake Pad

The main points for checking the front brake lining are to see whether the lining wear is out of the range. Replace the brake lining wear is out of the range. Replace the brake lining if the lining wear is beyond the brake wear limit mark.

▲ WARNING

If the brake system or brake linings have to be repaired, we suggest that these repair should be performed by your authorized SKYTEAM dealer. SKYTEAM dealer knows your motorcycle best and is dedicated to your complete satisfaction.

NOTICE

The high pressure brake is used by disc brake system. To ensure the safety, the replacement interval of oil pressure line and brake fluid should not be more than that stipulated in "MAINTENANCE SCHEDULE" of this manual.

Before riding the motorcycle, be sure to check daily the following items:

- (1) Check the front and rear brakes system for leakage of brake fluid.
- (2) Check the oil pressure line for leakage of fluid or tears.
- (3) Check the brake lever and brake pedal for free play.
- (4) Check the front and rear brakes lining for wear.

▲ WARNING

When the new brake lining begins to be used, don't ride your motorcycle immediately after the replacement. Apply the brake, release it, then spin the wheel and check that it rotates freely. Repeat this procedures several times and allow the brake fluid to circulate normally.

CLUTCH

Clutch adjustment may be required if the motorcycle stalls when shifting into gear or tends to creep; or if the clutch slips, causing acceleration to lag behind engine speed. Minor adjustments can be made with the clutch cable adjuster (4) at the lever (1).

Normal clutch lever free play is:
10-20mm (0.4-0.8in)

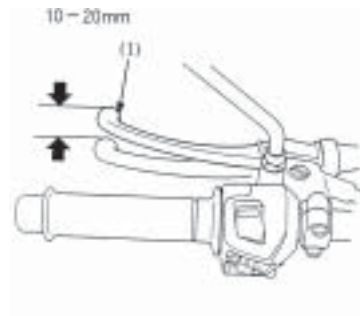

(1) Clutch lever

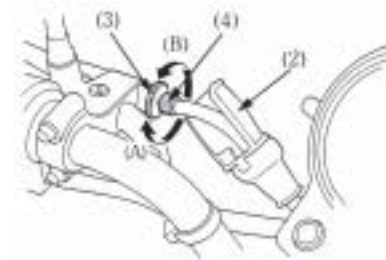

- (2) Dust cover
(3) Lock nut
(4) Clutch cable adjuster
(A) Decrease free play
(B) Increase free play

4. Loosen the lock nut (6) at the lower end of the cable. Turn the adjusting nut (5) to obtain the specified free play. Tighten the lock nut (6) and check the adjustment.

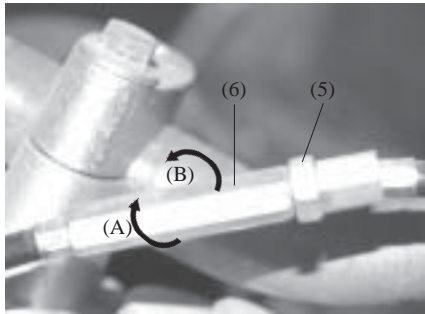

(5) Adjusting nut

(6) Lock nut

(A) Decrease free play

(B) Increase free play

5. Start the engine, pull in the clutch lever and shift into gear. Make sure the engine does not stall and the motorcycle does not creep. Gradually release the clutch lever and open the throttle. The motorcycle should begin to move smoothly and accelerate gradually.

If proper adjustment cannot be obtained or the clutch does not work correctly, see your SKYTEAM dealer.

Other Checks:

Check the clutch cable for kinks or signs of wear that could cause sticking or failure. Lubricate the clutch cable with a commercially available cable lubricant to prevent premature wear and corrosion.

FUEL

Fuel Valve

The three way fuel valve (1) is located on the left and down of the fuel tank.

OFF

With the fuel valve in the OFF position, fuel cannot flow from the tank to the carburetor. Turn the valve OFF whenever the motorcycle is not in use.

ON

With the fuel valve in the ON position, fuel will flow from the main fuel supply to the carburetor.

RES

With the fuel valve in the RES position, fuel will flow from the reserve fuel supply to the carburetor. Use the reserve fuel only when the main supply is gone. Refill the tank as soon as possible after switching to RES.

Remember to check that the fuel valve is in the ON position each time you refuel. IF the valve is left in the RES position, you may run out of fuel with no reserve.



(1) Fuel valve

Fuel Tank

The fuel tank capacity including the reserve supply is:

10L

To open the fuel fill cap(1), pull the breather tube (2) from the rubber cover(3). Turn the fuel fill cap counterclockwise.

After refueling, be sure to tighten the fuel fill cap firmly by turning it clockwise. Insert the breather tube into the rubber cover.

▲ WARNING

Petrol is highly flammable and explosive. You can be burned or seriously injured when handling fuel.

- Stop the engine and keep heat, sparks, and flame away.
- Refuel only outdoors.
- Wipe up spills immediately.

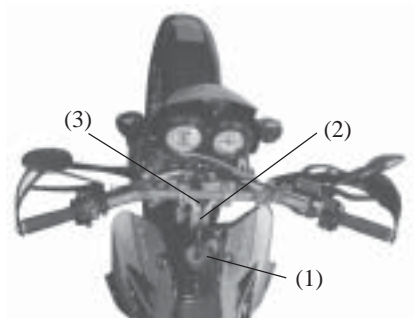

- (1)Fuel fill cap
- (2)Breather tube
- (3)Rubber cover

Use unleaded or low-lead petrol with a research octane number of 90 or higher. We recommend that you use unleaded petrol because it produces fewer engine and spark plug deposits and extends the life of exhaust system components.

NOTICE

If "spark knock" or "pinking" occurs at a steady engine speed under normal load, change brands of petrol. If spark knock or pinking persists, consult your SKYTEAM dealer. Failure to do so is considered misuse, and damage caused by misuse is not covered by SKYTEAM Limited Warranty.

Occasionally you may experience light spark knock while operating under heavy loads. This is no cause for concern, it simply means your engine is operating efficiently.

ENGINE OIL

Engine Oil Level Check

Check the engine oil level each day before operating the motorcycle.

The oil filler cap/dipstick (1) is at the rear of the right crankcase cover and contains a dipstick for measuring the oil level. Oil level must be maintained between the upper (2) and lower (3) level marks on the filler cap/dipstick (1).

1. Hold the motorcycle on upright firm level ground.

2. Start the engine and let it idle for a few minutes.

3. Stop the engine. After a few minutes, remove the oil filler cap/dipstick (1) and wipe it clean, then reinsert the dipstick without screwing it in. Remove the dipstick. The oil level should be between the upper (2) and lower (3) level marks on the dipstick.

4. If required, add the specified oil up to the upper level mark. Do not overfill.

5. Reinstall the oil filler cap/dipstick. Check for oil leaks.

NOTICE

Running the engine with insufficient oil can cause serious engine damage.

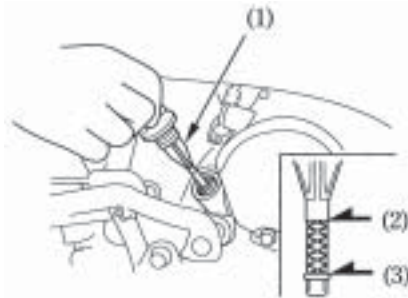

(1) Filler cap/dipstick (2) Upper level mark
(3) Lower level mark

TIRES

To safely operate your motorcycle, the tires must be the proper type and size, in good condition with adequate tread, and correctly inflated.

▲ WARNING

Using tires that are excessively worn or improperly inflated can cause a crash in which you can be seriously hurt or killed. Follow all instructions in this owner's manual regarding tire inflation and maintenance.

Air Pressure

Properly inflated tires provide the best combination of handling, tread life, and riding comfort. Generally, underinflated tires wear unevenly, adversely affect handling, and are more likely to fail from being overheated/ Underinflated tires can also cause wheel damage in rocky terrain. Overinflated tires make your motorcycle ride more harshly, are more prone to damage from surface hazards, and wear unevenly.

Make sure the valve stem caps are secure. If necessary, install a new cap.

Always check air pressure when your tires are "cold." If you check air pressure when your tires are "warm"-even if your motorcycle has only been ridden for a few miles-the readings will be higher. If you let air out of warm tires to match the recommended cold pressures, the tires will be underinflated.

The recommended "cold" tire pressures are:

front	100kpa(1.0kgf/cm ² ,15psi)
rear	125kpa(1.25kgf/cm ² ,18psi)

Inspection

Whenever you check the tire pressures, you should also examine the tire treads and sidewalls for wear, damage, and foreign objects:

Look for:

- Bumps or bulges in the side of the tire or the tread. Replace the tire if you find any bumps or bulges.
- Cuts, splits or cracks in the tire. Replace the tire if you can see fabric or cord.
- Excessive tread wear

Also if you hit a pothole or hard object, pull to the side of the road as soon as you safely can and carefully inspect the tires for damage.

Tread Wear

Replace tires before tread depth at the center of the tire reaches the following limit:

Minimum tread depth	
Front:	3.0mm(0.12in)
rear:	3.0mm(0.12in)

For TR/and OF

Minimum tread depth	
Front:	1.0mm(0.04in)
rear:	1.0mm(0.04in)

For SM

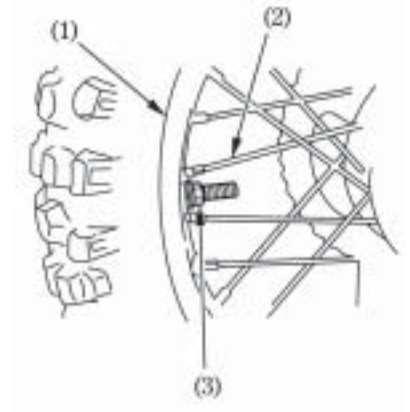

(1) Tire tread depth

Tube Repair and Replacement

If a tube is punctured or damaged, you should replace it as soon as possible. A tube that is repaired may not have the same reliability as a new one, and it may fail while you are riding.

If you need to make a temporary repair by patching a tube or using an aerosol sealant, ride cautiously at reduced speed and have the tube replaced before you ride again. Any time a tube is replaced, the tire should be carefully inspected.

Tire Replacement

The tires that came on your motorcycle were designed to match the performance capabilities of your motorcycle and provide the best combination of handling, braking, durability and comfort.

▲ WARNING

Installing improper tires on your motorcycle can affect handling and stability. This can cause a crash in which you can be seriously hurt or killed.

Always use the size and type of tires recommended in this owner's manual.

The recommended tires for your motorcycle are:

SM Front: 100/80-17
Rear: 120/80-17

TR Front: 3.0-21
Rear: 4.1-18

Whenever you replace a tire, use one that is equivalent to the original and be sure the wheel is balanced after the new tire is installed.

Also remember to replace the inner tube whenever you replace a tire. The old tube will probably be stretched, and if installed in a new tire, it could fail.

ESSENTIAL INDIVIDUAL COMPONENTS
IGNITION SWITCH

The ignition switch (1) is used to prevent unauthorized use of the motorcycle.
 Before riding, insert the key and turn it to the ON position.
 After parking the motorcycle, remove the key.

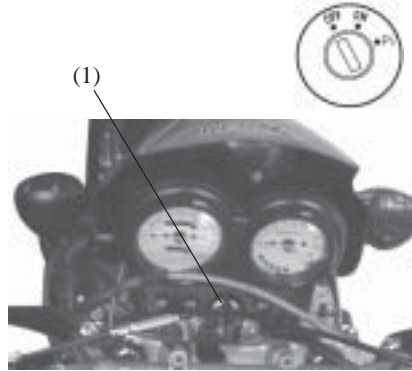

(1) Ignition switch

Key Position	Function	Key Removal
OFF	The engine cannot be operated.	Key can be removed
ON	With the transmission in neutral, the engine can be started.	Key cannot be removed
P	The night lamp can be used. The engine cannot be operated.	Key can be removed

INSTRUMENT PANEL

SPEEDOMETER(1)

The speedometer indicates the driving speed in kilometers per hour.

ODOMETER(2)

The odometer keep the record of the total distance that the motorcycle has run since it was used.

KNOB(3)

Rotating this knob, reserting the odometer (4) to zero indicating.

ODOMETER(4)

The odometer keep the record of the total kilometer between two places.

ENGINE SPEEDOMETER(5)

The speedometer indicates the engine speed in round per minute.

TURN SIGNAL INDICATOR LIGHT(6)

When operating the turn signal switch, this light comes on.

NEUTRAL INDICATOR LIGHT(7)

When the transmission is in neutral position, the green neutral indicator light comes on. When the transmission is not in neutral, the indicator won't flash.

HIGH BEAM INDICATOR LIGHT(8)

When operating the dimmer switch to "H" position or operating the pass switch, the light comes on.

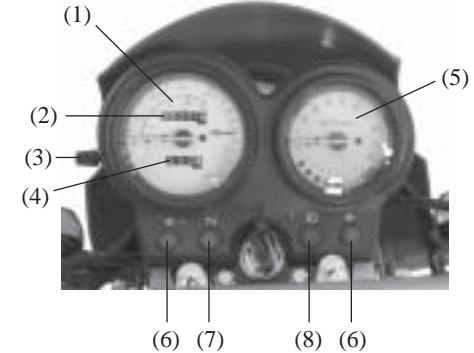

LEFT HANDLEBAR

PASS SWITCH(1)

Press this switch to apply passing operation.

Nighttime riding light switch(2)

"☀️": When the engine is running, the head light, instrument light and tail light come on simultaneously.

"🌙": No matter the engine runs or not, the head light, instrument light and tail light come on simultaneously.

"•": The head light, instrument light and tail light come off simultaneously.

HORN BUTTON(3)

Press the button and the horn will sounds.

TURN SIGNAL SWITCH(4)

When the switch in "👉" position, the left turn signal light starts flashing, When the switch is in "👈" position, the right turn signal light starts flashing. When the switch is in middle position, the turn signal lights do not work.

DIMMER SWITCH

Move the switch to "🔆" position, the head light high beam comes on. On the contrary, move the switch to "🔇" position, the low beam is on.

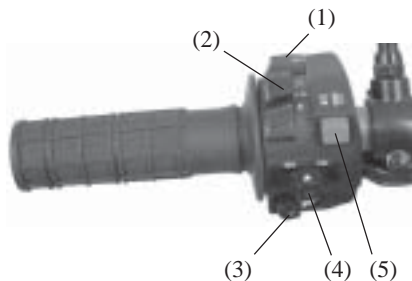

RIGHT HANDLEBAR

Front Brake Lever(1)

Grip the front break lever to break the front wheel.

EMERGENCY ENGINE STOP SWITCH(2)

In case of emergency, move this switch to left to disconnect the ignition line, letting the engine go out, when you start the engine move this switch to right.

Electrical Start Button(3)

Push down the electrical start button to start the engine.

Throttle Grip(4)

The throttle grip is used to control the engine speed. Twist it toward yourself to accelerate and turn it away from yourself to decelerate.

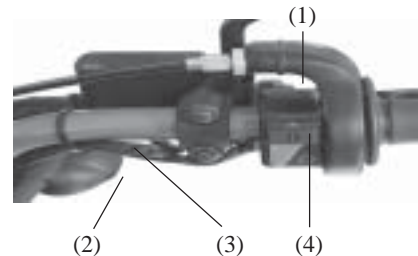

OPERATION

PRE-RIDE INSPECTION

For your safety, it is very important to take a few moments before each ride to walk around your motorcycle and check its condition. If you detect any problem, be sure you take care of it, or have it corrected by your SKY TEAM dealer.

▲ WARNING

Improperly maintaining this motorcycle or failing to correct a problem before riding can cause a crash in which you can be seriously hurt or killed.

Always perform a pre-ride inspection before every ride and correct any problems.

1. Engine oil level-add engine oil if required. Check for leaks.
2. Fuel level-fill fuel tank when necessary. Check for leaks.
3. Front and rear brakes-check operation and if necessary, adjust free play.
4. Tires-check condition and pressure.
5. Spokes and rim locks-check and tighten if necessary.
6. Drive chain-check condition and slack. Adjust and lubricate if necessary.
7. Chain slider-check slider wear.
8. Throttle-check for smooth opening and full closing in all steering positions. Adjust free play if necessary .

9. Clutch-check operation, and adjust if necessary.
10. Spark plug and high tension terminal-check for looseness.
11. Engine stop button-check for proper function.
12. Nuts, bolts, fasteners-check the front wheel to see that the axle nut and axle holder nuts are tightened securely. Check security of all other nuts, bolts, and fasteners.

STARTING THE ENGINE

Always follow the proper starting procedure described below.

Your motorcycle's exhaust contains poisonous carbon monoxide gas. High levels of carbon monoxide can collect rapidly in enclosed areas such as a garage. Do not run the engine with the garage door closed. Even with the door open, run the engine only long enough to move your motorcycle out of the garage.

Preparation

Before starting, insert the key and turn the ignition switch ON.

Make sure that the transmission is in neutral.
Turn the fuel valve ON.

Starting Procedure

To restart a warm engine, follow the procedure for "High Air Temperature".

Normal Air Temperature
10°–35° (50°–95°F)

1. Pull the choke level (1) up all the way to Fully OFF (A).

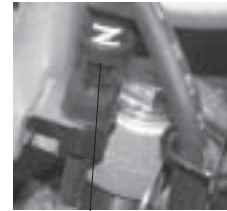

(B) Detent position

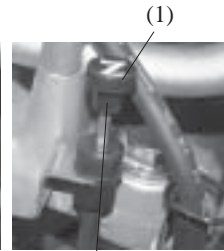

(A) Fully OFF

(1) Choke level

2. Keep the throttle fully closed.

3. Push the electric starter button or operate the kick starter to start the engine. Starting from the top of the stroke, kick through to the bottom with a rapid, continuous motion. Do not operate the throttle.

NOTICE

Allowing the kick starter to snap back freely against the pedal stop can damage the engine case.

4. Warm up the engine by opening and closing the throttle slightly.

About a quarter minute after the engine starts, push the choke level (1) down all the way to Fully ON(B).

5. If idling is unstable, open the throttle slightly.

High Air Temperature

35°(95°F) or above

1. Do not use the choke.
2. Keep the throttle fully closed.
3. Start the engine following step 3 under "Normal Air Temperature".

Low Air Temperature

10°(50°F) or below

1. Follow steps 1-2 under "Normal Air Temperature".
2. Warm up the engine by opening and closing the throttle slightly.
3. Continue warming up the engine until it runs smoothly and responds to the throttle when the choke lever(1) is at Fully ON(B).

NOTICE

Extended use of the choke may impair piston and cylinder wall lubrication and damage the engine.

FLOODED ENGINE

If the engine fails to start after repeated attempts, it may be flooded with excess fuel. To clear a flooded engine, push the choke lever down to Fully OFF (A). Open the throttle fully and crank the engine several times with the kick starter while moving the emergency engine stop switch to left. Moving the stop switch to right and follow the "High Air Temperature" Starting Procedure.

RUNNING-IN

Help assure your motorcycle's future reliability and performance by paying extra attention to how you ride during the first operating day or 25km (15miles).

During this period, avoid full-throttle starts and rapid acceleration.

RIDING

Review Motorcycle Safety before you ride.

Make sure the side stand is fully retracted before riding the motorcycle. If the stand is extended, it may interfere with control during a left turn.

Make sure you understand the function of the side stand mechanism.

1. After the engine has been warmed up, the motorcycle is ready for riding.
2. While the engine is idling, pull in the clutch lever and depress the gearshift pedal to shift into 1st (low) gear.

3. Slowly release the clutch lever and at the same time gradually increase engine speed by opening the throttle. Coordination of the throttle and clutch lever will assure a smooth positive start.
4. When the motorcycle attains a moderate speed, close the throttle, pull in the clutch lever and shift to 2nd gear by raising the gearshift pedal. This sequence is repeated to progressively shift to 3rd, 4th (top) gears.

5. Raise the pedal to shift to a higher gear and depress the pedal to shift to a lower gear. Each stroke of the pedal engages the next gear in sequence. The pedal automatically returns to the horizontal position when released.

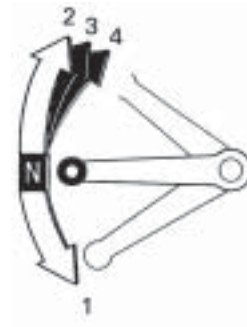

- Do not downshift when traveling at a speed that would force the engine to over rev in the next lower gear; the rear wheel may lose traction, resulting in a possible loss of vehicle control.
- Do not shift gears without disengaging the clutch and closing the throttle. The engine and drive train could be damaged by over speed and shock.
- Do not tow the motorcycle or coast for long distances while the engine is off. The transmission will not be properly lubricated and damage may result.
- Do not run the engine at high rpm with the transmission in neutral or the clutch lever pulled in. Serious engine damage may result.

HIGH ALTITUDE RIDING

When operating this motorcycle at high altitude the air-fuel mixture becomes overly rich. Driveability and performance may be reduced and fuel consumption increased. The carburetor can be modified to compensate for this high altitude richness, however it must be returned to standard specifications before extended operation at low altitudes (below 1,200m, 4,000feet). See your SKYTEAM dealer for this high altitude modification

NOTICE

Sustained operation at lower altitudes with high altitude carburetor modifications may cause engine overheating and damage.

BRAKING

For normal braking,gradually apply both the front and rear brakes while downshifting to suit your road speed.

For maximum deceleration,close the thrtle and apply the front and rear brakes firmly.Pull in the clutch lever before coming to a compete stop to prevent stalling the engine.

Important Safery Reminders:

- Independent operation of only the brake lever or brake pedal reduces stopping performance.
- Extreme application of the brake controls may cause wheel lock, reducing control of the motorcycle.

- When possible,reduce speed or brake before entering a turn. Closing the throttle or braking in mid-turn may cause wheel slip.Wheel slip will reduce control of the motorcycle.

- When riding in wet or rainy conditions,or on loose surfaces,the ability to maneuver and stop will be reduced .All of your actions should be smooth under these conditions.Rapid acceleration,braking or turning may cause loss of control. For your safety,exercise extreme caution when braking,accelerating or turning.

- When descending along, steep grade, use engine compression braking by down-shifting, with intermittent use of both brakes. Continuous brake application can overheat the brakes and reduce their effectiveness.

PARKING

1. After stopping the motorcycle, shift the transmission into neutral and turn the fuel valve OFF. Push the engine stop button in and hold it in until the engine stops completely.

2 Use the side stand to support the motorcycle while parked.

Park the motorcycle on firm, level ground to prevent it from falling over.

If you must park on a slight incline, aim the front of the motorcycle uphill to reduce the possibility of rolling off the side stand or over turning.

3. Turn the ignition switch OFF and remove the key.

ANTI-THEFT TIPS

1. Be sure the registration information for your motorcycle is accurate and current.

2. Park your motorcycle in a locked garage whenever possible.

3. Use an additional anti-theft device of good quality.

4. Put your name, address and phone number in this Owner's Manual and keep it on your motorcycle at all times. Many times stolen motorcycles are identified by information in the Owner's Manuals which are still with them.

NAME: _____

ADDRESS: _____

PHONE NO: _____

MAINTENANCE

THE IMPORTANCE OF MAINTENANCE

A well-maintained motorcycle is essential for safe, economical, and trouble-free riding. It will also help reduce air pollution. Careful pre ride inspections and good maintenance are especially important.

To help you properly care for your motorcycle, this section of the manual provides a Maintenance Schedule.

The service intervals in this schedule are based on average riding conditions.

More frequent service is needed if you subject your motorcycle to severe use (such as competition) or ride in unusually wet or dusty areas.

Frequent servicing of the air cleaner is especially important to help you avoid a possible costly engine repair.

If your motorcycle overturns or becomes involved in a crash, be sure your SKYTEAM dealer inspects all major parts, even if you are able to make some repairs.

⚠ WARNING

Improperly maintaining this motorcycle or failing to correct a problem before you ride can cause a crash in which you can be seriously hurt or killed.

Always follow the inspection and maintenance recommendations and schedules in this owner's manual.

MAINTENANCE SAFETY

This section includes instructions on some important maintenance tasks. You can perform some of these tasks with the tools provided-if you have basic mechanical skills.

Other tasks that are more difficult and require special tools are best performed by professionals. Wheel removal should normally be handled only by a SKYTEAM technician or other qualified mechanic; instructions are included in this manual only to assist in emergency service.

However, we cannot warn you of every conceivable hazard that can arise in performing maintenance. Only you can decide whether or not you should perform a given task.

▲ WARNING

Failure to properly follow maintenance instructions and precautions can cause you to be seriously hurt or killed.

Always follow the procedures and precautions in this owner's manual.

SAFETY PRECAUTIONS

- Make sure the engine is off before you begin any maintenance or repairs. This will help eliminate several potential hazards:

- * **Carbon monoxide poisoning from engine exhaust.**

Be sure there is adequate ventilation whenever you operate the engine.

- * **Burns from hot parts.**

Let the engine and exhaust system cool before touching.

- * **Injury from moving parts.**

Do not run the engine unless instructed to do so.

- Read the instructions before you begin, and make sure you have the tools and skills required.

- To help prevent the motorcycle from falling over, park it on a firm, level surface, using the side stand or a maintenance stand to provide support.

- To reduce the possibility of a fire or explosion, be careful when working around petrol. Use only nonflammable solvent, not petrol, to clean parts. Keep cigarettes, sparks and flames away from all fuel-related parts.

Remember that your SKYTEAM dealer knows your motorcycle best and is fully equipped to maintain and repair it.

To ensure the best quality and reliability use only new genuine SKYTEAM parts or their equivalents for repair and replacement.

MAINTENANCE SCHEDULE

Perform the Pre-ride Inspection at each scheduled maintenance period.

I: INSPECT AND CLEAN, ADJUST, LUBRICATE OR REPLACE IF NECESSARY

C: CLEAN R: REPLACE A: ADJUST L: LUBRECATE

The following Maintenance Schedule specifies all maintenance required to keep your motorcycle in peak operating condition. Maintenance work should be performed in accordance with standards and specifications of SKYTEAM by properly trained and equipped technicians. Your SKYTEAM dealer meets all of these requirements.

* Should be serviced by your SKYTEAM dealer, unless the owner has the proper tools and service data and is mechanically qualified.

**In the interest of safety, we recommend these items be serviced only by your SKYTEAM dealer

SKYTEAM recommends that your SKYTEAM dealer should road test your motorcycle after each periodic maintenance is carried out.

NOTE:(1)service more frequently when ridden in wet or dusty conditions.

ITEMS	FREQUENCY	WHICHEVER	INITIAL	REGULAR			
		COMES →	MAINT.	NAINT.INTERVAL			
		FIRST		1,000	2,000	3,000	4,000
		km	150	1,000	2,000	3,000	4,000
		mi	100	600	1,200	1,800	2,400
		NOTE MONTH	1	6	12	18	24
* FUEL LINE					I		I
** FUEL STRAINER SCREEN					C		C
* THROTTLE OPERATION					I		I
AIR CLEANER	NOTE(1)			C	C	C	C
SPARK PLUG				I	I	I	I
* VALVE CLEARANCE			I	I	I	I	I
ENGINE OIL			R	R	R	R	R
** ENGINE OIL/STRAINER SCREEN					C		C
* CAM CHAIN TENSION			A	A	A	A	A
** ENGINE IDLE SPEED			I	I	I	I	I

ITEMS	FREQUENCY	WHICHEVER COMES →		INITIAL MAINT.	REGULAR NAINT.INTERVAL			
		FIRST	km	150	1,000	2,000	3,000	4,000
		↓	mi	100	600	1,200	1,800	2,400
	NOTE	MONTH	1	6	12	18	24	
DRIVE CHAIN		NOTE(1)		I,L	Every 1,600km(1,000mi)or every 100 operating hours:C			
DRIVE CHAIN SLIDER					I	I	I	I
BRAKE SHOE WEAR					I	I	I	I
BRAKE SYSTEM				I	I	I	I	I
CLUTCH SYSTEM				I	I	I	I	I
SIDE STAND						I		I
* SUSPENSION						I		I
* NUTS,BOLT,FASTENERS				I		I		I
** WHEELS/TIRES				I	I	I	I	I
** STEERING HEAD BEARINGS				I		I		I

SERIAL NUMBERS

The frame and engine serial numbers are required when registering your motorcycle.They may also be required by your dealer when ordering replacement parts.

Record the numbers here for your reference

FRAME NO. _____

ENGINE NO. _____

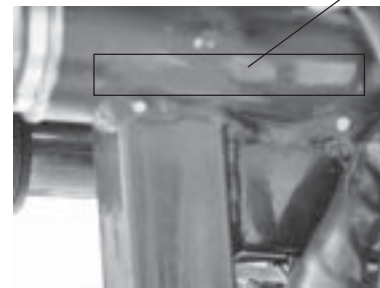

(1) frame number

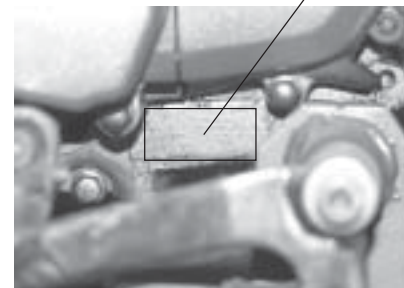

(2)engine number

The frame number(1) is stamped on the left side of the steering head.

The engine number(2) is stamped on the left side of the engine.

AIR CLEANER

The air cleaner should be serviced at regular intervals. Service more frequently when riding in unusually wet or dusty areas.

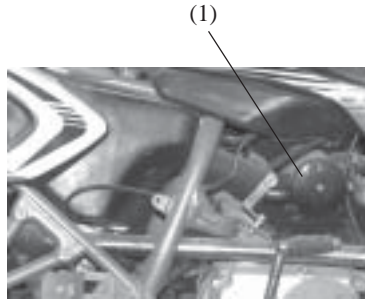

(1) Air cleaner

1. Wash the air cleaner in clean nonflammable or high flash point solvent and let dry thoroughly.

Never use petrol or low flash point solvents for cleaning the air cleaner. A fire or explosion could result.

2. Soak the air cleaner in gear oil until saturated, then squeeze out the excess oil.

3. Reinstall the air cleaner.

4. Reinstall the right side cover.

ENGINE OIL

Refer to the Safety Precautions.

Engine Oil

Good engine oil has many desirable qualities. Use only high detergent, quality motor oil certified on the container to meet or exceed requirements for API Service Classification SE, SF or SG.

Viscosity:

Viscosity grade of engine oil should be based on average atmospheric temperature in your riding area. The following provides a guide to the selection of the proper grade or viscosity of oil to be used at various atmospheric temperatures.

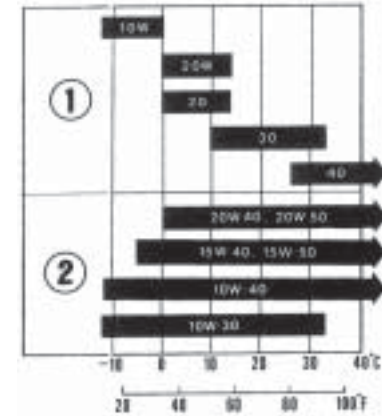

(1) Single grade (2) Multi grade

Engine oil

Engine oil quality is the chief factor affecting engine service life. Change the engine oil as specified in the maintenance schedule.

When running in very dusty conditions oil changes should be performed more frequently than specified in the maintenance schedule.

Please dispose of used engine oil in a manner that is compatible with the environment. We suggest you take it in a sealed container to your local recycling center or service station for reclamation. Do not throw it in the trash or pour it on the ground or down a drain.

Used engine oil may cause skin cancer if repeatedly left in contact with the skin for prolonged periods. Although this is unlikely unless you handle used oil on a daily basis, it is still advisable to thoroughly wash your hands with soap and water as soon as possible after handling used oil.

If a torque wrench is not used for this installation, see your SKYTEAM dealer as soon as possible to verify proper assembly.

Change the engine oil with the engine at normal operating temperature and the motorcycle on its side stand to assure complete and rapid draining.

TRANSMISSION OIL (SHIFTING GEAR OIL)

After a long time driving, the shifting gear oil in the transmission may degrade, which could reduce the lubricating performance of the oil. Therefore, after first 1000km driving and afterwards every 6000km, change the oil according to the following instructions.

Changing the lubeoil in the engine should be carried out when the engine is warm.

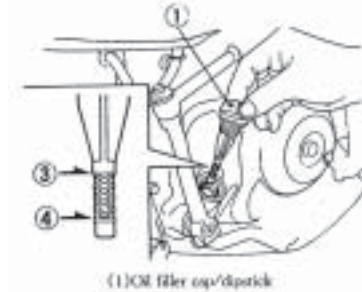

Remove the engine oil filler cap/dipstick then the drain cock to drain the oil fully. The used oil drainage should be carried out. Then refit the drain cock, pour the new lubeoil by the oil filler hole. Check the lubeoil level with a dipstick: insert a dipstick into the gear box, the oil level should be between the marks and (Do not screw in the dipstick into the hole).

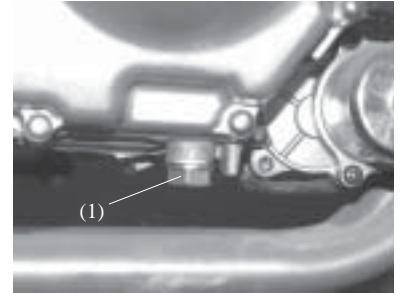

(2) Oil drain plug

SPARK PLUG

Recommended plugs:
Standard:D8RC

For most riding conditions this spark plug heat range number is satisfactory. However, if the motorcycle is going to be operated for extended periods at high speeds or near maximum power in hot climates, the spark plug should be changed to a colder heat range(a higher number).

NOTICE

Never use a spark plug with an improper heat range. Severe engine damage could result.

1. Disconnect the spark plug cap.
2. Clean any dirt from around the spark plug base.
3. Remove the spark plug.
4. Usually inspect the spark plug electrodes for wear, The center electrode should have square edges and the side electrode should not be eroded.
5. Discard the spark plug if there in apparent wear or if the insulator is cracked or chipped.

6. Check the spark plug gap(1) using a wire-type feeler gauge. if adjustment is necessary, bend the side electrode(2) carefully.
The gap should be:
0.6-0.7mm(0.02-0.03in)

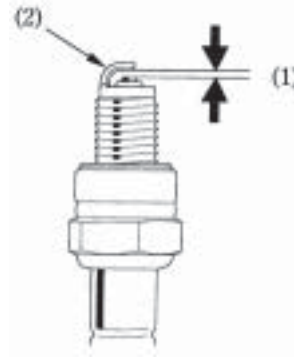

(1)Spark plug gap
(2)Side electrode

7. Make sure the plug washer is in good condition.
8. With the plug washer attached, thread the spark plug in by hand to prevent cross-threading.
9. Tighten a new spark plug 1/2 turn with a spark plug wrench to compress the washer. If you are reusing a plug, it should only take 1/8-1/4 turn after the plug seats.

NOTICE

The spark plug must be securely tightened. An improperly tightened plug can become very hot and possibly damage the engine.

10. Reinstall the spark plug cap.

IDLE SPEED

Idle speed:

The engine must be at normal operating temperature for accurate idle speed adjustment. Ten minutes of stop-and-go riding is sufficient.

Do not attempt to compensate for faults in other systems by adjusting idle speed. See your SKYTEAM dealer for regularly scheduled carburetor adjustments.

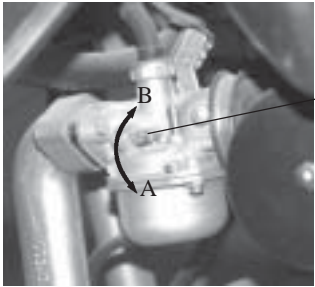

(1) Throttle stop screw (A) Increase
(B) Decrease

1. Warm up the engine and hold the motorcycle upright.
2. Connect a tachometer to the engine.
3. Adjust idle speed with the throttle stop screw(1).

Idle speed(In neutral):
 $1,350 \pm 100 \text{min}^{-1}(\text{rpm})$

THROTTLE OPERATION

Cable Inspection:

1. Check for smooth rotation of the throttle grip from the fully open to the fully closed position at both full steering positions.
2. Inspect the condition of the throttle cable from the throttle grip down to the carburetor. If the cable is kinked, chafed or improperly routed, it should be replaced and/or rerouted.
3. Lubricate the cable with a commercially available cable lubricant to prevent premature wear and corrosion.

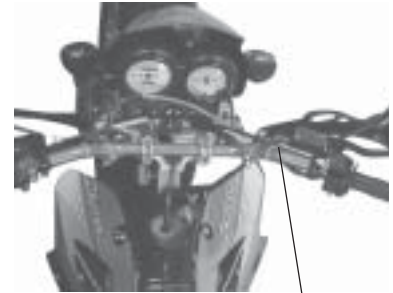

(1) Throttle cable

4. Adjust free play with the throttle cable adjuster (2). Measured in grip rotation, the standard throttle grip free play is:
2-6mm(0.1-0.2in)

5. To adjust the free play, loosen the lock nut(3) and turn the adjuster(2).

6. After adjustment, check again for smooth rotation of the throttle grip from the fully closed to the fully open position with the steering to the full right and left as well as straight ahead.

If proper throttle free play cannot be achieved, contact your SKYTEAM dealer.

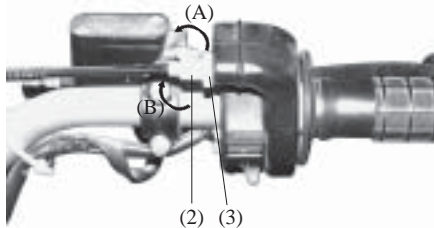

(2) Adjuster
(3) Lock nut

(A) Decrease free play
(B) Increase free play

DRIVE CHAIN

The service life of the drive chain is dependent upon proper lubrication and adjustment. Poor maintenance can cause premature wear or damage to the drive chain and sprockets.

The drive chain should be checked and lubricated as part of the Pre-ride Inspection. Under severe usage, or when the motorcycle is ridden in unusually dusty or muddy areas, more frequent maintenance will be necessary.

Inspection:

1. Turn the engine off, place the motorcycle on its side stand and shift the transmission into neutral.

2. Check slack in the lower drive chain run midway between the sprockets.

Drive chain slack should be adjusted to allow the following vertical movement by hand:
25-35mm(1.0-1.4in)

3. Roll the motorcycle forward, stop, and then check the drive chain slack. Repeat this procedure several times. Drive chain slack should remain constant. If the chain is slack only in certain sections, some links are kinked and binding. Binding and kinking can frequently be eliminated by lubrication.

NOTICE

Excessive chain slack may allow the drive chain to damage the engine cases

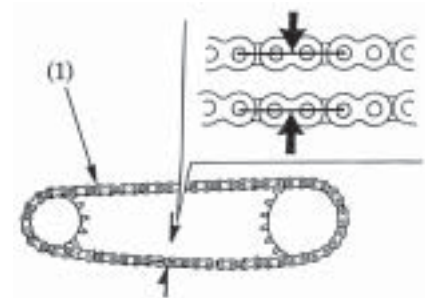

(1) Drive chain

4. Check the chain slider(2) for wear.

If the depth of groove exceeds the limit, the chain slider must be replaced. See your SKYTEAM dealer.

Chain slider depth limit:
6mm(0.2in)

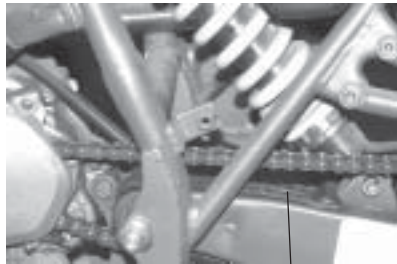

(2)Chain slider

(2)

5. Measure a section of the drive chain to determine whether the chain is worn beyond its service limit. Remove the drive chain and measure the distance between a span of pins from pin center to pin center. If the distance exceeds the service limit, the chain is worn out and should be replaced.

6. Inspect the sprocket teeth for possible wear or damage.

Damaged sprocket
Teeth
Replace

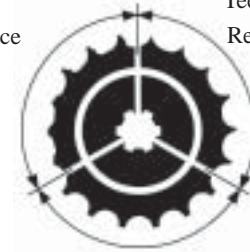

Worn sprocket
Teeth
Replace

Normal sprocket Teeth
Good

If the drive chain or sprockets are excessively worn or damaged, they should be replaced. Never use a new chain with worn sprockets; rapid chain wear will result.

Adjustment:

If the drive chain requires adjustment, the procedure is as follows;

1. Place a support block under the engine to raise the rear wheel off the ground.
2. Loosen the rear axle nut(1).

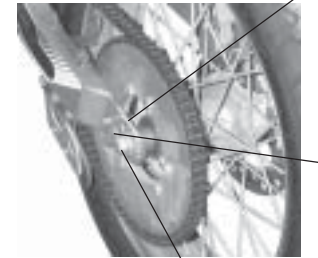

(1)Rear axle nut
(2)Adjuster

(3)Adjuster index mark

(1)

(3)

(2)

3. Turn the both the right and left chain adjusters(2) to an equal number of turns to increase or decrease chain slack. Align the chain adjuster index marks(3)with the same mark on both sides of the swing arm.
4. Tighten the axle nut
5. Recheck drive chain slack.
6. Rear brake pedal free play is affected when repositioning the rear wheel to adjust drive chain slack. Check rear brake pedal free play and adjust as necessary.

If a torque wrench is not used for this installation, see your SKYTEAM dealer as soon as possible to verify proper assembly.

Lubrication:

Use SAE 80 or 90 gear oil or a commercially prepared drive chain lubricants in preference to motor oil or other lubricants. Saturate each chain link joint so that the lubricant penetrates between the link plates, pins, bushings, and rollers.



Removal and Cleaning:

When the drive chain becomes dirty, it should be removed and cleaned prior to lubrication.

1. With the engine off, carefully remove the master link retaining clip with a pair of pliers. Do not bend or twist the clip. Remove the master link. Remove the drive chain from the motorcycle.
2. Clean the drive chain in high flash-point solvent and allow it to dry. Inspect the drive chain for possible wear or damage. Replace any chain that has damaged rollers, loose fitting links, or otherwise appears unserviceable. Never use petrol or low flash point solvents for cleaning the drive chain. A fire or explosion could result.
3. Inspect the sprocket teeth for possible wear or damage.
4. Lubricate the drive chain.

5. Pass the chain over the sprockets and join the ends of the chain with the master link. For ease of assembly, hold the chain ends against adjacent rear sprocket teeth while inserting the master link.

The master link is the most critical part affecting the security of the drive chain. Master links are reusable, if they remain in excellent condition, but it is recommended that a new master link retaining clip be installed whenever the drive chain is reassembled.

Install the master link retaining clip so that the closed end of the clip will face the direction of forward wheel rotation.



(1) Retaining clip

WHEEL RIMS AND SPOKES

1. Inspect the wheel rims (1) and spokes (2) for damage.
2. Tighten any loose spokes and rim locks (3).
3. Check wheel rim runout. If runout is noticeable, see your SKYTEAM dealer for inspection.

Maintenance of spoke tension and wheel trueness are critical to safe motorcycle cooperation. During the first 150 km (100 miles), spokes will loosen more rapidly due to initial seating of parts. Excessively loose spokes may result in high speed instability and possible loss of control.

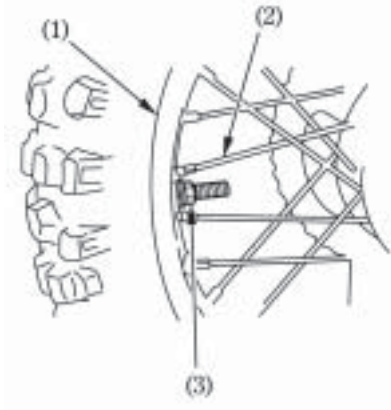

(1) Wheel
(2) Spoke
(3) Rim lock

WHEEL REMOVAL

Front Wheel Removal

1. Raise the front wheel off the ground by placing a support block under the engine.
2. Remove the front axle (1). The front wheel can now be removed.



(1) Front axle

Installation Notes:

To install the front wheel assembly reverse the removal procedure.

Be sure to tighten the axle nut to:
62 n.m (6.3 kgf.m, 46 lbf.ft)

Check front brake.

After installing the wheel, apply the brake several times and then check if the wheel rotates freely. Recheck the wheel if the brake drags or if the wheel does not rotate freely.

Rear Wheel Removal

1. Raise the rear wheel off the ground by placing a support block under the engine.
2. Unscrew the axle nut (1) and pull out the axle. Push the wheel forward and derail the drive chain from the rear sprocket. Tilt the motorcycle to one side so that the wheel can be removed.



(1)

(1) Axle nut

Installation Notes:

To install the rear wheel, reverse the removal procedure. Make sure that the plug (5) on the swing arm is located in the slot (6) in the brake panel. Tighten the axle nut to:

62 N.m (6.3 kfg.m, 46 lbf.ft)

Adjust the drive chain

Adjust the brake

Apply the brake several times and check for free wheel rotation after the brake pedal is released.

If a torque wrench was not used for installation, see your SKYTEAM dealer as soon as possible to verify proper assembly. Improper assembly may lead to loss of braking capacity.

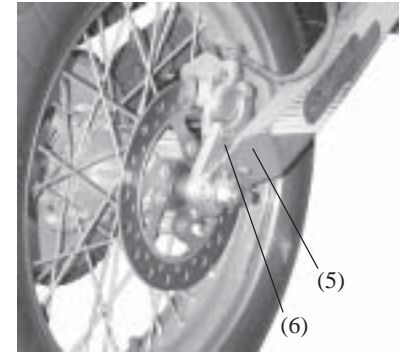

(5) Plug

(6) Slot

FRONT SUSPENSION

Check the fork operation by locking the front brake and pumping the forks up and down several times. The suspension should function smoothly, with no oil leakage from the fork legs. Damaged, binding, or leaking fork should be repaired before the motorcycle is operated. Check security of all fork and handlebar mounting bolts (1).

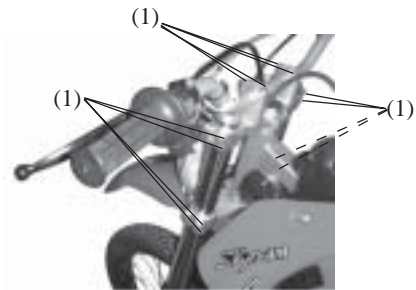

(1) Mounting bolts

Operating the motorcycle with loose, worn, or damaged steering or front suspension components may adversely affect vehicle handling and stability.

If any suspension components appear worn or damaged, consult your SKYTEAM dealer for further inspection. The suspension components are directly related to safety and your SKYTEAM dealer is qualified to determine whether or not replacement parts or repairs are needed.

REAR SUSPENSION

Check the rear suspension periodically by careful visual examination. Note the following items:

1. Swingarm bushings (1) should be checked by pushing hard against the side of the rear wheel while the motorcycle is on a support block and feeling for looseness of the bushings.
2. Check all suspension component attachment points for security of their fasteners (2).
3. Check for oil leaks in the shock absorber units.

If any suspension components appear worn or damaged, consult your SKYTEAM dealer for further inspection. The suspension components are directly related to safety and your SKYTEAM dealer is qualified to determine whether or not replacement parts or repairs are needed.

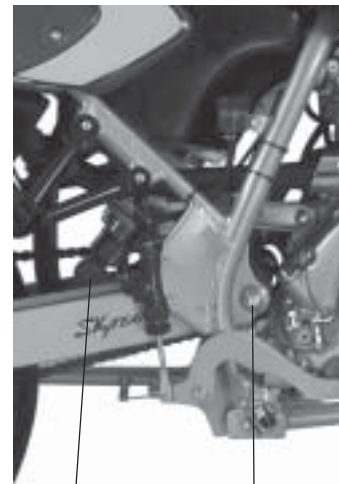

(1) Swingarm bushings
(2) Fasteners

SIDE STAND

Check the side stand spring for damage and loss of tension, and the side stand assembly for freedom of movement.

If the side stand is squeaky or stiff, clean the pivot area and lubricate the pivot bolt with clean engine oil.

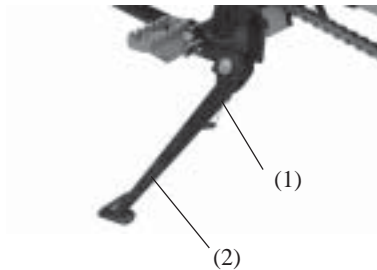

(1) Side stand spring

(2) Side stand

CLEANING

Clean your motorcycle regularly to protect the surface finishes and inspect for damage, wear and oil leakage.

Avoid cleaning products that are not specifically designed for motorcycle or automobile surfaces. They may contain harsh detergents or chemical solvents that could damage the metal, paint, and plastic on your motorcycle.

If your motorcycle is still warm from recent operation, give the engine and exhaust system time to cool off.

We recommend avoiding the use of high pressure water spray (typical in coin operated car washes).

NOTICE

High pressure water (or air) can damage certain parts of the motorcycle.

High pressure washer spray can damage certain parts of your motorcycle. If you use a high pressure washer, avoid spraying the following areas:

- Wheel Hubs
- Muffler Outlet
- Under Seat
- Engine Stop Button
- Under Fuel Tank
- Drive Chain
- Carburetor
- Ignition Switch

Washing the motorcycle

1. Rinse the motorcycle thoroughly with cool water to remove loose dirt.

2. Clean the motorcycle with a sponge or soft cloth using cool water.

Avoid directing water to muffler outlets and electrical parts.

3. Clean the plastic parts using a cloth or sponge dampened with a solution of mild detergent and water. Rub the soiled area gently rinsing it frequently with fresh water.

Take care to keep brake fluid or chemical solvents off the motorcycle.

They will damage the plastic and painted surfaces.

4. After cleaning, rinse the motorcycle thoroughly with plenty of clean water. Strong detergent residue can corrode alloy parts.

5. Dry the motorcycle, start the engine, and let it run for several minutes.

6. Test the brakes before riding the motorcycle. Several applications may be necessary to restore normal braking performance.

7. Lubricate the drive chain immediately after washing and drying the motorcycle.

Braking efficiency may be temporarily impaired immediately after washing the motorcycle. Anticipate longer stopping distance to avoid a possible accident.

Finishing Touches

After washing your motorcycle, consider using a commercially-available spray cleaner/polish or quality liquid or paste wax to finish the job. Use only a non-abrasive polish or wax made specifically for motorcycles or automobiles. Apply the polish or wax according to the instructions on the container.

STORAGE GUIDE

Extended storage, such as for winter, requires that you take certain steps to reduce the effects of the motorcycle. In addition, necessary repairs should be made **BEFORE** storing the motorcycle; otherwise, these repairs may be forgotten by the time the motorcycle is removed from storage.

STORAGE

1. Change the engine oil.
2. Drain the fuel tank and carburetor into an approved petrol container.
Reinstall the fuel fill cap on the tank.

If storage will last more than one month, carburetor draining is very important, to assure proper performance after storage.

▲ WARNING

Petrol is highly flammable and explosive, you can be burned or seriously injured when handling fuel.

- Stop the engine and keep heat, sparks, and flame away.
- Refuel only outdoors.
- Wipe up spills immediately.

3. To prevent rusting in the cylinder, perform the following:

- Remove the spark plug cap from the spark plug. Using tape or string, secure the cap to any convenient plastic body part so that it is positioned away from the spark plug.
- Remove the spark plug from the engine and store it in a safe place. Do not connect the spark plug to the spark plug cap.
 - Pour a tablespoon (15-20cm³) of clean engine oil into the cylinder and cover the spark plug hole with a piece of cloth.
 - Crank the engine several times to distribute the oil.
 - Reinstall the spark plug and spark plug cap

4. Wash and dry the motorcycle. Wax all painted surfaces. Coat chrome with rust inhibiting oil.

5. Lubricate the drive chain

6. Inflate the tires to their recommended pressures. Place the motorcycle on blocks to raise both tires off the ground.

7. Cover the motorcycle (don't use plastic or other coated materials) and store in an unheated area, free of dampness with a minimum of daily temperature variation. Do not store the motorcycle in direct sunlight.

REMOVAL FROM STORAGE

1. Uncover and clean the motorcycle.
Change the engine oil if more than 4 months have passed since the start of storage.
2. Perform all Pre-ride Inspection checks.
3. Test ride the motorcycle at low speeds in a safe riding area away from traffic.

SPECIFICATIONS

DIMENSIONS

Overall length	TR:2150mm	SM:2080mm
Overall width ⁸	830mm	
Overall height	TR:1230mm	SM:1210mm
Wheelbase	1460mm	

WEIGHT

Dry weight	115kg
------------	-------

MAIN PERFORMANCE PARAMETERS

Fuel consumption at economical speed	1.5L: 100km	
Max. speed	type I:45km/h	type II:25km/h
Rated power	type I:2.5kw(7500rpm)	type II:1.9kw(6500rpm)
Max. torque	type I:2.5N.m(6000rpm)	type II:2.5N.m(5100rpm)
Idle speed	1350 ± 100rpm	

CAPACITIES

Fuel tank	10L
Passenger capacity	75kg

ENGINE

Bore and stroke	39mm × 41.4mm
Compression ratio	8.8:1
Displacement	49cm ³
Spark plug	A7RTC
Valve clearance(Cold)	Intake: 0.05mm Exhaust: 0.05mm

ELECTRICAL

Ignition type	CDI
Generator	Magneto
Battery	12V 6Ah
Head light	12V 35W/35W
Turning signal indicator light	12V 10W
Tail/brake light	12V 21W/5W
Instrument indicator light	12V 3W, 12V 1.7W
Horn	12V 1.5A 95dB(A)
Fuse	10A

CHASSIS AND SUSPENSION

Caster	25°	
Tire size, front	TR:3.0-21	SM:100/80-17
Tire size, rear	TR:4.1-18	SM:120/80-17

POWER TRANSMISSION

Gear ratio,1st	36/11
2nd	31/18
3rd	25/21
4th	22/20
Final reduction	62/13

All information,illustration, photographs and specifications contained in this manual are based on the latest product information available at time of publication. Due to improvements or other changes, there may be some discrepancies in this manual . SKYTEAM reserve the right to make changes at any time without notice.